

McHale

V8

VARIABLE
CHAMBER
BALER RANGE



WWW.MCHALE.NET

The Professional Choice



McHALE VARIABLE CHAMBER BALER RANGE

Over the last decade the McHale range of balers have been operating in over 6 continents in some of the world's most difficult conditions. McHale balers have developed a reputation for providing **HIGH OUTPUT, EXCELLENT RELIABILITY, OPERATOR COMFORT AND TOP RESALE VALUE.**

CONTENTS

INTRODUCTION	1 - 2
V8 Variable Baler Range	3 - 4
Inner Workings	5 - 6
Pick-Up	7 - 8
Split Drive Gearbox / Rotor	9 - 10
Chopper Unit	11 - 12
Drop Floor	13 - 14
Bale Chamber	15 - 17
Oiling & Greasing	18
High Performance Netter	19 - 20
Expert Plus Control Console	21 - 22
Options	23 - 24
Tech Table	25

TWO MODELS

A RANGE TO MEET YOUR NEEDS

*The variable chamber round baler range has been designed with the demands of today's **FARMER AND CONTRACTOR IN MIND**. This common sense approach to design ensures that their operation is **KEPT SIMPLE AND USER FRIENDLY**.*

All the balers in the V8 variable chamber baler range make bales from **0.6—1.9m (2'—6'3")**. The McHale **V8 variable chamber baler range** consists of 2 models;

V8940 – Non-Chopper Baler

V8950 – Chopper Baler

Offering innovative ideas to allow you to work smarter, whilst achieving more output, the McHale name has become synonymous with the production of robust and reliable machines, making McHale the number one choice for professional users.

McHale make a high output baler to suit everyone's needs. Whether it is a non-chopper V8940 baler or a 15 knife chopper V8950 baler, there is a host of options to choose from to suit your individual needs.



THE MCHALE V8940 is a non-chopper variable chamber baler that is equipped with a high intake feed rotor to ensure even and efficient crop flow to the bale chamber. The McHale V8940 is driven by a primary drive system for optimum bale formation. Central grease blocks are fitted on the machine for greasing whilst oiling is controlled through the continuous oiling system. Net and bale density can be adjusted from the cab through the Expert Plus control console. The machine is fitted with 460/65-20 tyres as standard.

BALE SIZE
Unwrapped
All forage types

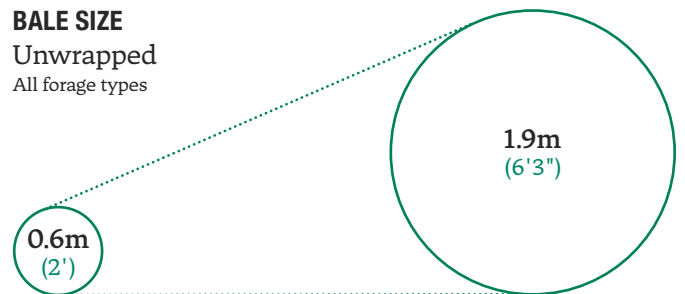

01 2.1m PICK-UP
High-Intake Pick-Up
with Galvanised Bands

02 FEED ROTOR
High Intake
Feed Rotor

03 CHOPPER UNIT
Non-Chopper

04 DRIVE SYSTEM
Primary Drive

05 CONTROL SYSTEM
Expert Plus

06 GREASING
Centralised
Greasing Blocks

V8
950

THE MCHALE V8950 is a semi-automatic variable chamber baler which is fitted with a 15 knife chopper unit and heavy-duty rotor. It is equipped with a double drive system which allows the machine to operate in the toughest of conditions. The double drive system aids belt rotation and bale formation. The machine comes with centralised grease blocks as standard. Automatic greasing is available as an option on all V8950 machines. Net and bale density can be adjusted from the cab through the Expert Plus control console. The machine is fitted with 500/50-22.5 tyres as standard.

BALE SIZE
Unwrapped
All forage types

0.6m
(2')

1.9m
(6'3")



01 2.1m PICK-UP
High-Intake Pick-Up
with Galvanised Bands

02 FEED ROTOR
15 Knife
Heavy-Duty Rotor

03 CHOPPER UNIT
15 Knife
Chopper Unit

04 DRIVE SYSTEM
Double Drive

05 CONTROL SYSTEM
Expert Plus

06 GREASING
Centralised
Greasing Blocks

Higher specification over the V8940

THE INNER WORKINGS

DRIVE SIDE

The **MACHINE GUARDING** on the variable chamber baler range has been designed using a durable twin skin composite. Once the guarding of the machine is opened up, it gives the **OPERATOR EASY ACCESS TO THE MACHINE COMPONENTS.**

01 Continuous Oiling System
Once the PTO is engaged, all chains receive oil continuously to ensure the highest standards of reliability.

04 High Performance Stretch Net System
A simple yet effective netting system allows the roll of net to rotate as it is being applied to ensure even net application.

02 Two Roll Net Loading & Storage
The operator simply releases the straps on the spare roll of net on the machine platform and moves the roll of net into position. Storage for two extra rolls of net is provided on the baler platform.

05

Bale Chamber Double Drive
On the McHale V8950, the double drive aids belt & material rotation in more difficult conditions.

06

Heavy-Duty Chains
Heavy-duty drive chains ensure long life with minimum down time.

07

Greasing
All drive and non-drive side chamber bearings and rotor bearings are being greased as the machine is working through the greasing cycle. As standard on all V8940 and V8950 machines, there is a number of centralised greasing blocks.
Automatic greasing is an available option on the V8950.

08

Mechanical Tailgate Locking
The bale chamber is kept securely closed with mechanical locks that open only to release the bale. Resulting in maximum baling density.

09

15 Knife Chopper Unit
The 15 knife chopper unit is the standard chopper unit in the McHale V8950. A bank of 15 knives provide a chop length of approximately 65mm.

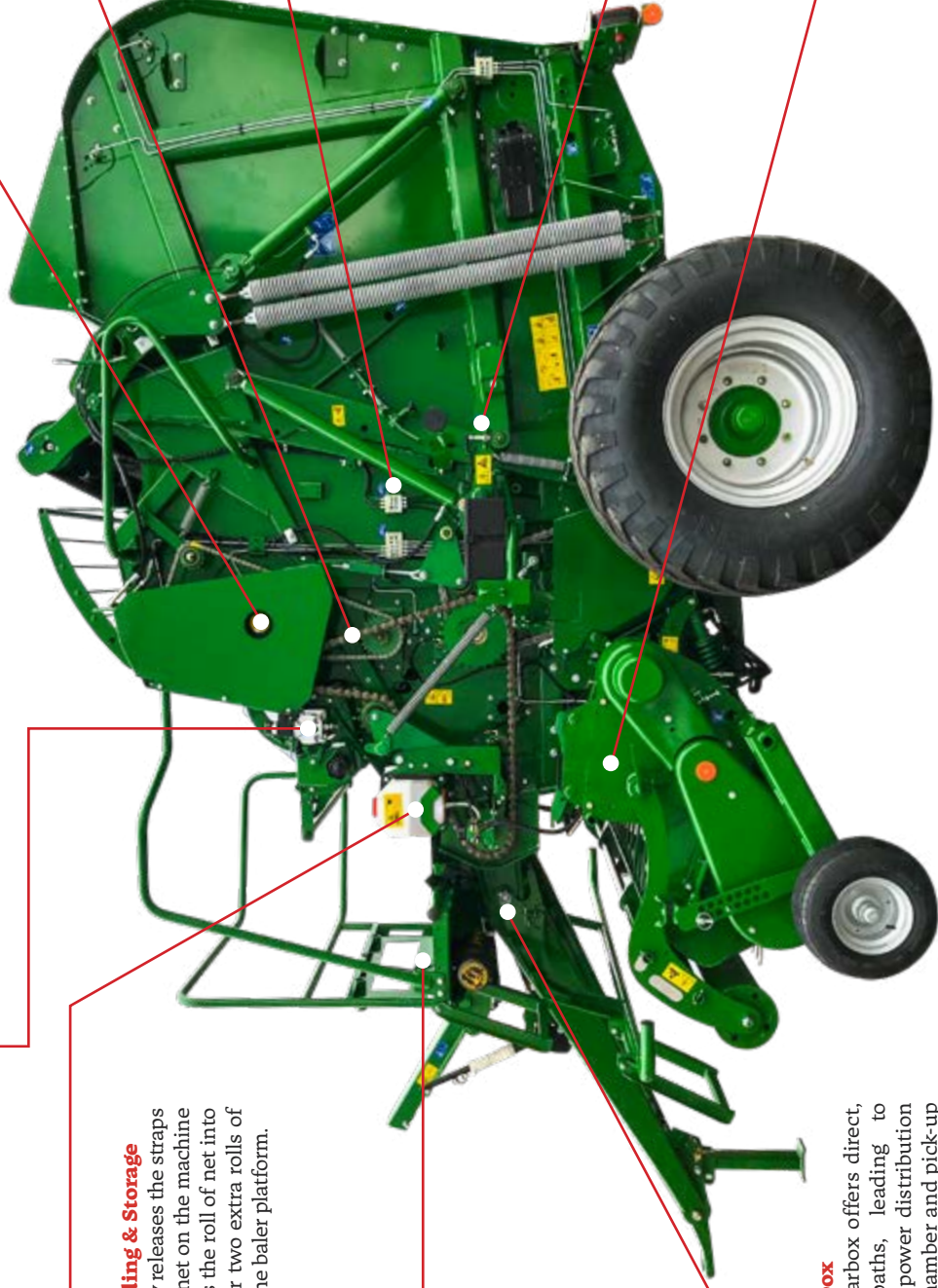

03 Split Drive Gearbox
The split drive gearbox offers direct, short transfer paths, leading to optimal and even power distribution to both the bale chamber and pick-up / chopper units.

THE INNER WORKINGS

NON-DRIVE SIDE

10

Cleaning Augers

A cleaning auger is fitted to the double drive which prevents crop build up. When the machine works in wet and sugary crops, the cleaning auger keeps the double drive clean.

11

Heavy-Duty Springs

4 heavy-duty springs pressurise the crop at the start of the baling process. The tension placed on the belts by these large springs allows for the perfect start to the bale as the operator can start at full speed. The spring tension on the belts ensures easy bale formation and a well formed core.

12

Simple Belt Tracking Adjustment

Belts can be simply adjusted at the rear of the machine to ensure for optimum bale formation.

13

Heavy-Duty 8 Stud Axle

The heavy-duty axle design gives greater ground clearance and the 8 stud axle configuration ensures the axle stands up to the most testing ground conditions.

14

Bale Shape Indicators

The bale shape indicators ensure that when the machine works in a light swath, the best bale shape is achieved by alerting the driver via the control console, which side of the chamber needs to be filled.

15

Central Greasing for Ram Ends & Door Hinges

A central greasing block allows the operator to easily supply grease to the door rams and hinges.

16

Drop Floor & Knife Position Sensors

Two sensors ensure that the machine always delivers a good chop quality. A drop floor sensor indicates to the operator if the floor is open via the control console while the knife position sensor monitors the distance between the top of the knife and the spine on the rotor.

17

2.1 Metre Pick-Up

As standard, a 2.1m high intake galvanised pick-up ensures excellent ground cleaning in all types of crop.

A camless pick-up is also available as an option.

18

Drop Floor Unblocking

The McHale variable chamber baler range is fitted with a drop floor unblocking system, which means blockages can be fed through in three simple steps.

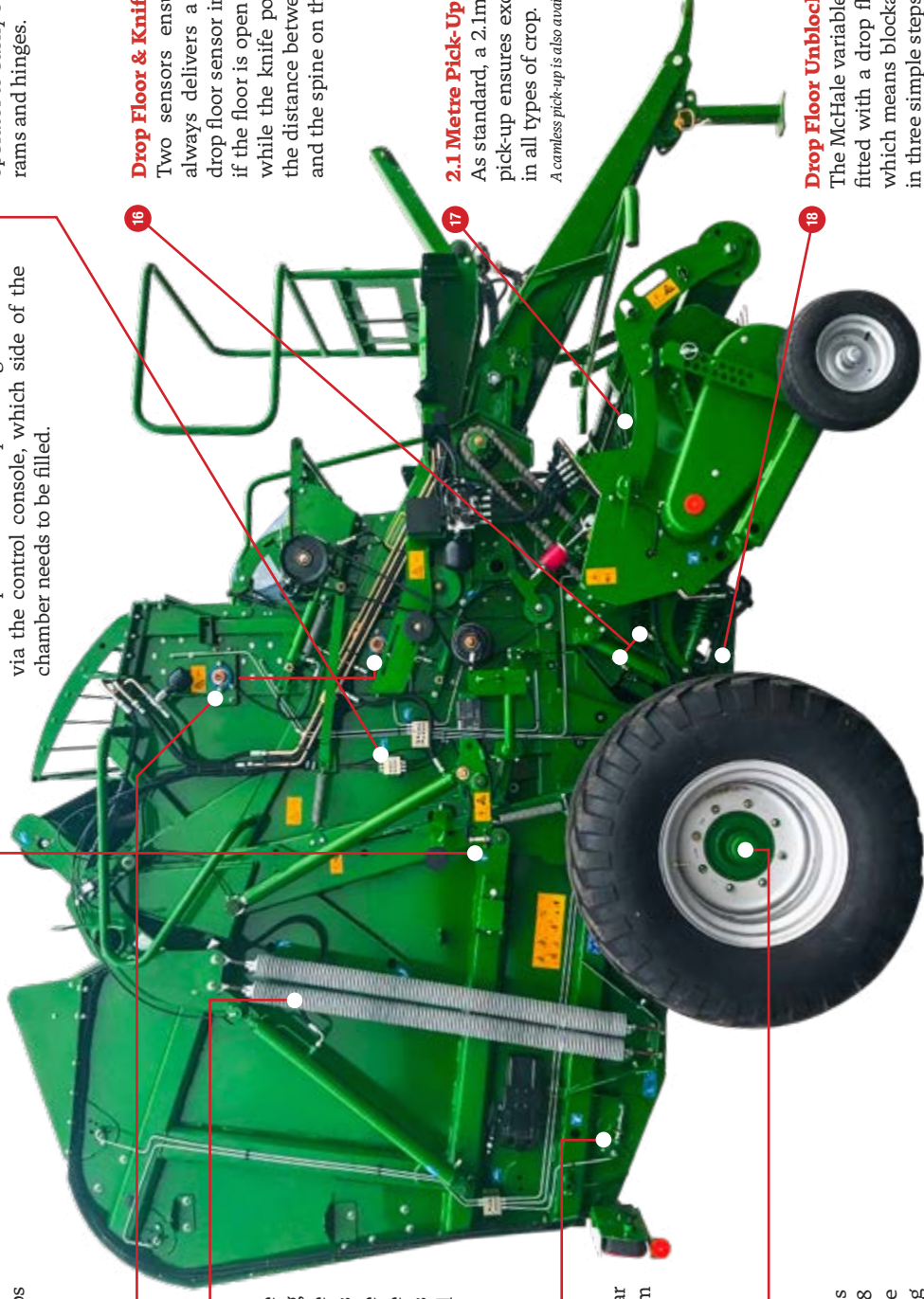

PICK-UP

Over the last decade, McHale have developed various types of pick-ups. After extensive testing, McHale decided it would offer customers the **CHOICE OF 2 PICK-UP OPTIONS** depending on their conditions;

1 Cam Pick-Up

As standard, a cam operated **2.1m high-intake galvanised** pick-up ensures excellent ground cleaning in all types of crop. The cam pick-up runs on a cam track that is fitted with **double raced cam bearings** to stand up to the most testing of conditions. All pick-ups across the McHale variable chamber baler range are fitted with 5 tine bars for excellent delivery of crop to the bale chamber. The 2.1 metre galvanised pick-up will lift even the shortest of crop.

A **side inspection port** allows the operator to quickly check and change the cam bearings.



2 Camless Pick-Up

A 2.1m camless pick-up is available as an option on all machines in the variable chamber baler range. Six tine bars are fitted to all McHale camless pick-ups to provide excellent ground cleaning and fast delivery of crop to the chamber. The new camless pick-up has been designed for increased output, with that in mind the cam-track free pick-up is more reliable, consists of less moving parts and is maintenance free.

For more information please see the range of options available on [page 23](#).



All McHale pick-ups come with a number of **STANDARD FEATURES THAT INCLUDE:**

01 Heavy-Duty Pick-Up

All McHale pick-ups feature heavy-duty tine bar supports to ensure long service life. A vital part of the pick-up is the tine, McHale have developed a pick-up tine designed to lift even the shortest of crop.

02 Efficient Crop Flow Delivery

The specially designed McHale pick-up is positioned close to the rotor to improve delivery of the crop through the rotor to the bale chamber. Large diameter lateral feed augers help direct crop to the bale chamber ensuring a consistent and even crop flow for producing high density bales.

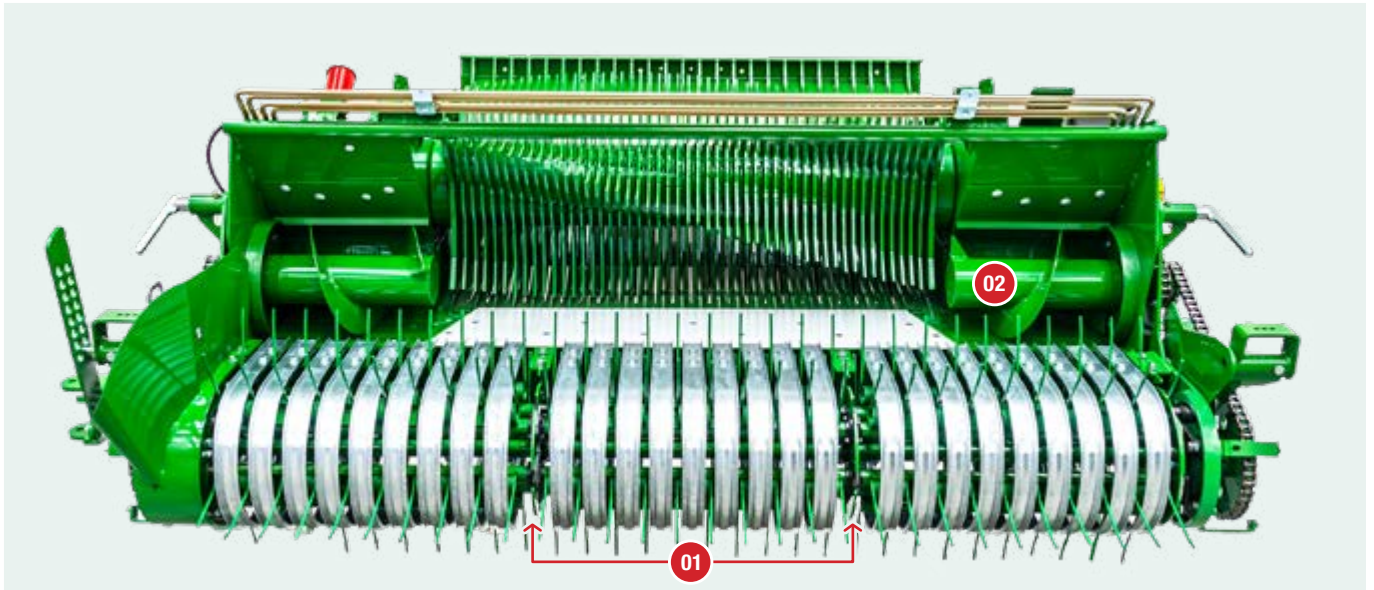

03 Adaptive Intake

Over the course of a baling season, machines have to work with different volumes of crop. McHale have designed an adaptive intake which allows the intake area to automatically adjust for light and heavy crops. This avoids peak loads and results in higher daily throughput regardless of working conditions.

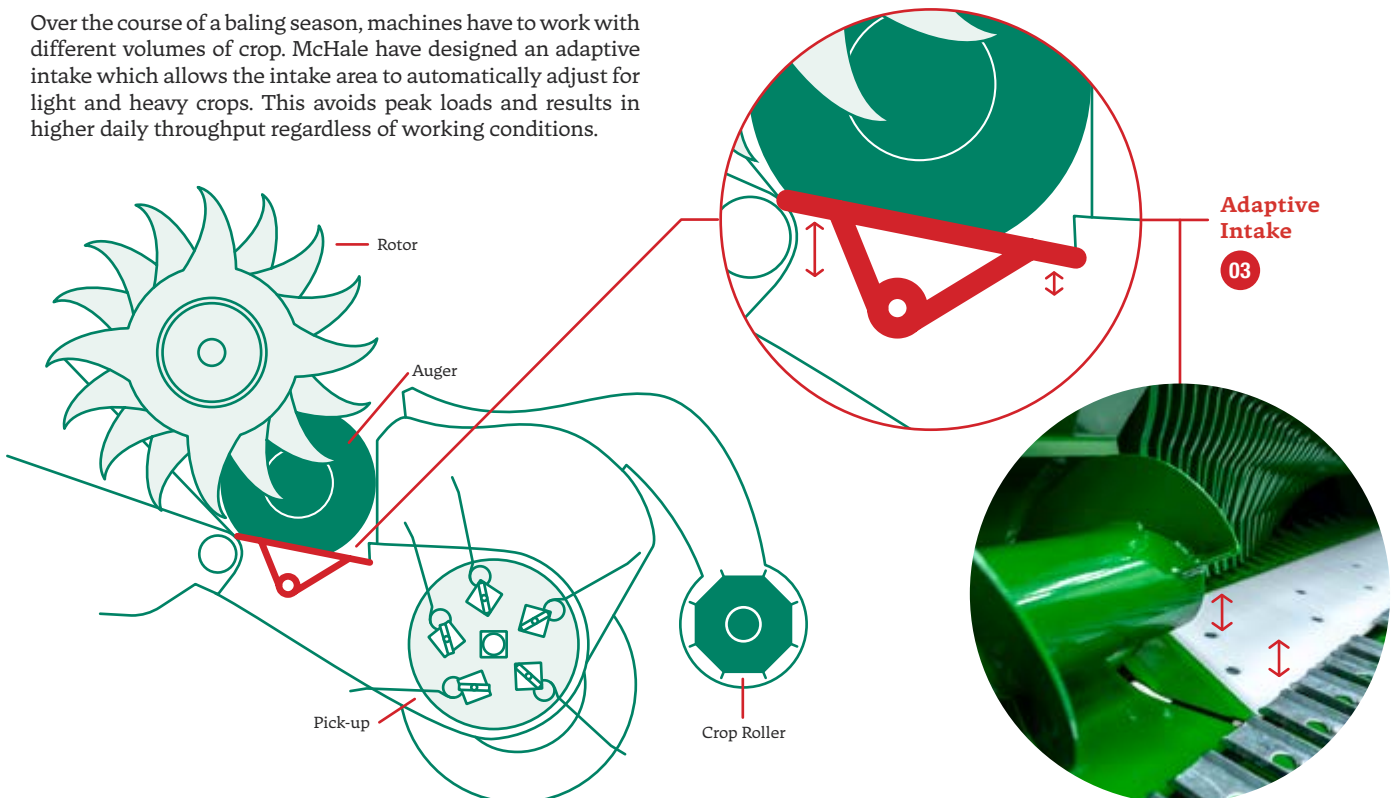

SPLIT DRIVE GEARBOX

A SPLIT DRIVE GEARBOX is fitted to all machines in the *McHale variable chamber baler range*.

The gearbox design ensures that power is evenly distributed to both sides of the baler. The belts in the bale chamber are driven from the left hand side of the machine, and the pickup and chopper unit are driven from the right hand side of the machine. This system ensures direct, short transfer paths, leading to optimal power distribution.

McHale machines work in different conditions around the world. In order to optimise machine performance, a 1000rpm gearbox is available as an optional upgrade on all machines in the McHale V8 variable chamber baler range.

We recommend you speak with your local dealer or distributor regarding which gearbox is better suited to your requirements based on your working conditions.

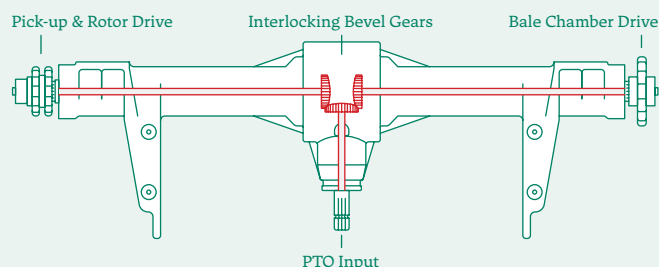

ROTOR

The star shaped feed rotors ensure a HIGH-CAPACITY FLOW of grass into the bale chamber.

The flights on the rotors are laid out in a spiral formation to achieve consistent crop flow. As crop enters the rotor, rotating flights feed the crop to the bale chamber. The flights on the rotor ensure high output, while the star layout reduces the load peaks as the machines work in heavy swaths. **McHale have designed three rotors for the variable chamber baler range:**

1 *Non-Chopper Twin Finger Rotor*



2 *15 Knife Chopper Rotor*



3 *25 Knife Chopper Rotor*

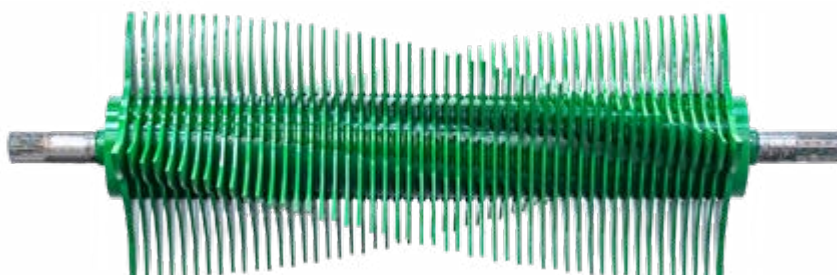



BENEFITS OF CHOPPING SILAGE

Across the world, the benefits of baled silage can be seen. By also chopping the crop in baled silage, it delivers the following benefits;

BETTER QUALITY

The quality of the crop is enhanced by chopping as chopped crop is easier to compress to form heavy, dense bales that are much tighter due to the air being expelled from the bale. This also leads to a reduction in transport and net costs.

BETTER FERMENTATION

Chopping allows for the crop to ferment better as the sugars in the crop will be readily available from the dry grass. This will result in the production of superior quality fodder that will be easily digestible for your animals.

EASIER FEED OUT

Chopped forage is easier to distribute from diet feeders and straw blowers. Short material can be processed and distributed from diet feeders and straw blowers much faster than longer material.

The feed rotor or chopping unit boasts a **heavy-duty rotor and comb**. The flights are **welded on both sides** for superior strength and on the drive side the rotor is fitted with a **double row bearing** with a long service life.



Rotor Type	Machine	Rotor Formation	Flight Thickness	Number of Knives	Selectable Knives
Non Chopper	Standard: V8940	Spiral	Inner: 8mm Outer: 12mm	0	Not Available
15 Knife Chopper	Standard: V8950	Spiral	Inner: 8mm Outer: 12mm	15	Optional
25 Knife Chopper	Optional: V8950	Spiral	Inner: 6mm Outer: 12mm	25	Optional

V8950 CHOPPER UNITS

To ensure a consistent and even chop quality, **TWO CHOPPING OPTIONS** have been developed for the McHale V8950 variable chamber baler machines.

1 15 Knife Chopper Unit

The 15 knife chopper unit is the standard chopper unit on the **McHale V8950**. A bank of 15 knives provides a chop length of approximately 65mm.



2 25 Knife Chopper Unit

The 25 knife chopper unit is available as an option on the **McHale V8950**. A bank of 25 knives provides a chop length of approximately 46mm.

For more information please see the range of options available on [page 23](#).

Selectable Knife System

All McHale V8950 machines have the option to be fitted with a **selectable knife system**. Various knife configurations can be chosen depending on the knife bank specification as **shown in these charts** with **red and blue lines indicating individual knives**;

15 Knife Bank Options - 0, 7, 8, 15

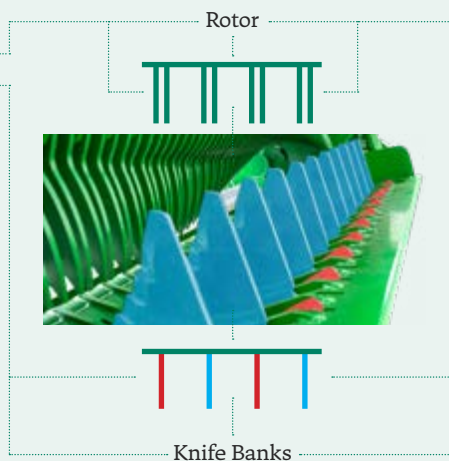
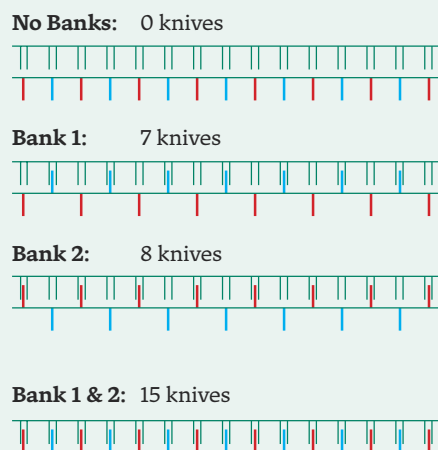

25 Knife Bank Options - 0, 12, 13, 25

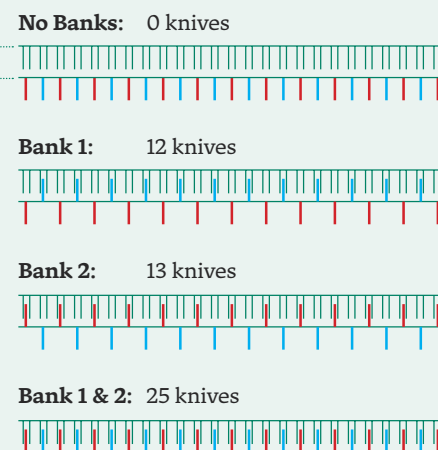

For more information please see the range of options available on [page 23](#).

Knives

The knives in the chopping unit are made from hardened tool steel, which ensures long life and maximum productivity, by reducing the downtime associated with knife sharpening.

Chop Quality

The knives in the chopping unit can be engaged and disengaged from the tractor cab. When engaged, the knives extend into the spine of the rotor, which ensures a consistent chop quality. A primary hydraulic knife protection system protects the knife bank(s) should it encounter a foreign object. A secondary protection system is in place on each individual knife.

Consistent Results

To ensure that the machine always delivers a good chop quality, two monitoring systems have been put in place on the V8950. Firstly, knife working pressure is monitored and displayed on the control box. Secondly, a sensor monitors the distance between the top of the knife and the spine on the rotor.

BENEFITS OF SELECTABLE KNIVES

ADJUSTABLE CHOP LENGTH

With selectable knives, the operator can vary their chop length by engaging or disengaging either knife bank. If fine chopping is required, the operator can choose to engage both knife banks. A reduction in chop length can also be quickly and easily achieved without the operator having to remove knives.

CONSISTENTLY SHARP KNIVES

When the operator is using only one half of the knife bank, the second half of the knife bank can be easily engaged to provide consistently sharp knives. By having consistently sharp knives, fuel consumption is reduced as the machine does not struggle to chop the crop.

OPERATOR COMFORT

Without the operator having to physically replace knives, a new sharp set of knives can be engaged, ensuring a well chopped crop and continued high output. Should different chop lengths be required the operator can make the adjustments without having to alter the knives.



DROP FLOOR UNBLOCKING THREE SIMPLE STEPS

For over a decade, all machines in the variable chamber baler range are fitted with the McHale **DROP FLOOR UNBLOCKING SYSTEM**, a feature which operators have come to love for its simplicity of use and effective unblocking cycle.

As baling conditions are not always ideal, uneven swaths can occur which can lead to blockages. The McHale variable chamber baler range is fitted with a drop floor unblocking system, which means blockages can be fed through in **three simple steps**.

1 Drop the Floor

Should a blockage occur, the sound of the slip clutch alerts the operator, who can hydraulically lower the floor from the tractor cab.

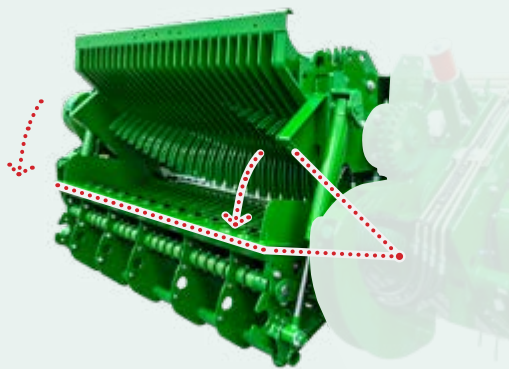

2 Re-engage the PTO

This widens the feed channel and on re-engaging the PTO, the blockage can be fed through.



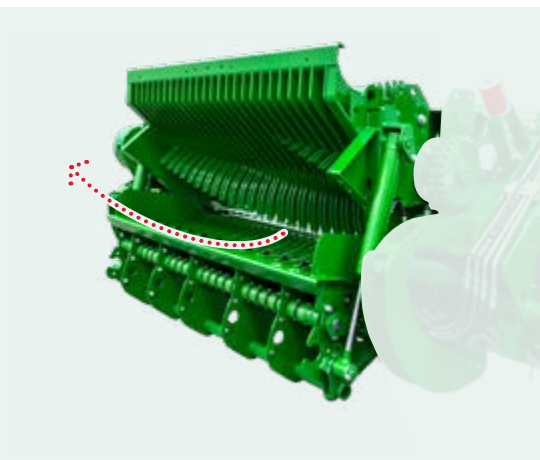

3 *Reset the Floor*

The floor can then be reset to its original position and baling can resume.



Features of the Drop Floor

When operating the drop floor cycle on the variable chamber baler range, the knives and the drop floor drop together during the unblocking process, giving even more clearance to allow the blockage to be fed through.

On the variable chamber machines, the drop floor is equipped with a drop floor sensor to ensure the chop quality is consistent by indicating to the operator via the control console if the drop floor is open and the knives are down.



Drop Floor Sensor

BALE CHAMBER & BALE SIZES

The bale chamber on the McHale variable chamber baler range is comprised of **HEAVY-DUTY ENDLESS BELTS**. The belts are extremely hard wearing and are reinforced

with synthetic material, which ensures that the belts can **ABSORB AND APPLY HIGH PRESSURE** to the material in the bale chamber.



V8940 & V8950

The **V8940 & V8950** balers can make a bale from **0.6m (2')** to **1.9m (6'3")**.

Unwrapped

All forage types

0.6m
(2')

1.9m
(6'3")

Size increments

The bale size on **all of these machines** can be adjusted up from the minimum setting in **increments of 10mm (2/5")**

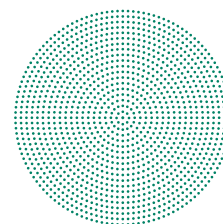

BALE CHAMBER BALE FORMATION

01 McHale have developed a bale chamber that can quickly form the bale from the start. The operator can commence baling at full speed as the **progressive density system** can quickly adjust to ensure that pressure is exerted on the crop right from the core of the bale, regardless of bale size.

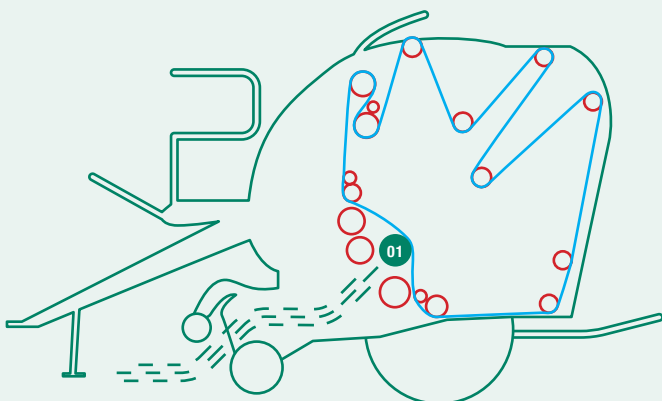

02 This is done by **four heavy-duty springs** that pressurise the crop at the start of the baling process. The tension placed on the crop by these large springs allows for the perfect start to the bale. The spring tension on the belts ensures easy bale formation and a properly formed core.

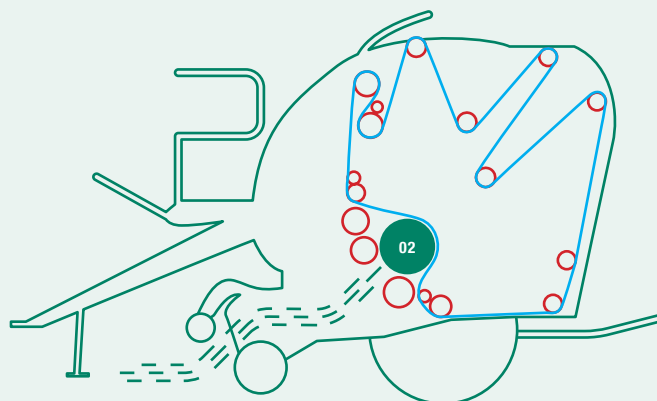



03 As the bale is forming inside the chamber, the hydraulics take over the tensioning of the belts from the four large springs. Two hydraulic rams control the tension on the chamber belts as the bale forms inside the chamber.

04 Just like the core of the bale, the outer layers are compressed at the same consistent pressure using both springs and hydraulics until the set bale density and size is reached.

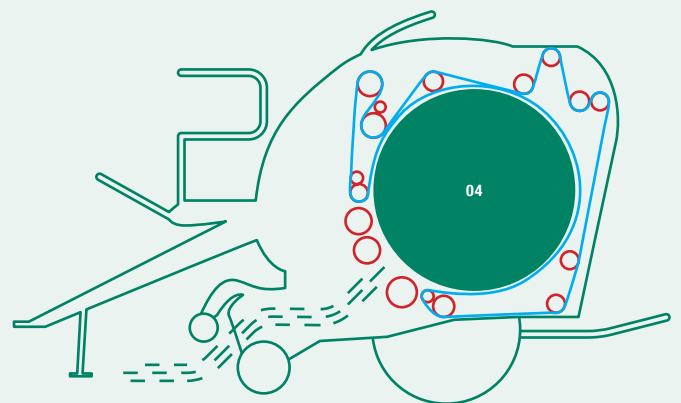
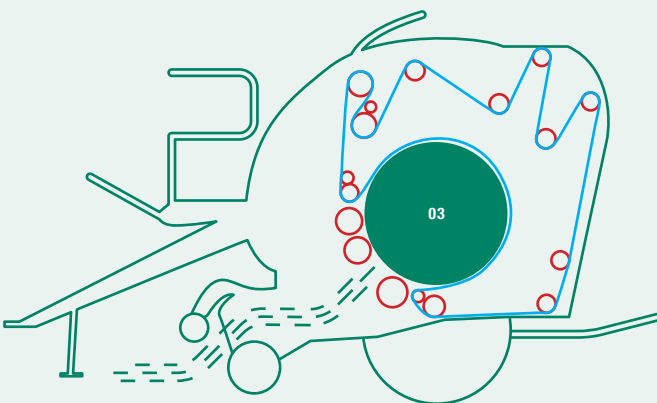

BALE CHAMBER DOUBLE DRIVE

A heavy-duty drive system powers belt and bale rotation on all machines in the variable chamber baler range. A primary drive system powers the belts on all McHale V8940 machines. On all McHale V8950 machines, a **DOUBLE DRIVE SYSTEM** is fitted to ensure belt rotation and bale formation.

Double Drive

In more difficult conditions, such as wet heavy grass, if the primary drive slips slightly, the double drive will engage in order to aid belt and material rotation in the chamber. This double drive helps bale formation as a constant pressure is kept on the chamber belts which results in the production of a solid and uniform bale even when dealing with a wet and heavy crop.

A cleaning auger is fitted to the double drive system in order to prevent crop build up and allow the double drive to aid bale rotation when working in wet or sugary crops.

Bale Shape Indicators

All machines in the McHale V8 variable chamber baler range are fitted with load sensing bale shape indicators that directly measure the bale pressure inside the chamber. By comparing the loading on each side of the chamber, the bale shape is calculated and then indicated to the operator via the control console, which side of the chamber needs to be filled. This direct measuring of the chamber pressure allows the bale shape indicators to be extremely accurate and responsive.

Mechanical Tailgate Locking System

The tailgates on all McHale variable chamber balers are fitted with a pair of mechanical locks, which keep the bale chamber securely closed. These locks remain activated until, the progressive density system reaches the preset bale size and density and the required amount of net has been applied. This eliminates the need for the chamber door to rely on hydraulic pressure when making high density bales.

Double Drive



Mechanical Tailgate Locks



BALE CHAMBER - HEAVY-DUTY BELTS

Three Endless Belts

All **V8 variable chamber balers** are equipped with **3 heavy-duty endless belts** as standard. These strong belts exert a high pressure on the bale in order to form a dense bale in the chamber. These belts are manufactured to the highest of standards using layers of synthetic and rubber material to form a durable endless belt with no joins.



OILING & GREASING

Continuous Oiling System

The McHale variable chamber baler range of balers are all fitted with a continuous oiling system. Once the PTO is engaged, the continuous oiling system **constantly lubricates the chains** to ensure a long lifetime. The continuous oiling system on the machine is driven off the gearbox and delivers oil to **the following chains**:

1 Chamber Drive Side Chains

2 Rotor Drive Chain

3 Pick-Up Drive Chains

4 Pick-Up Cam Track

5 Pick-Up Drive Gears

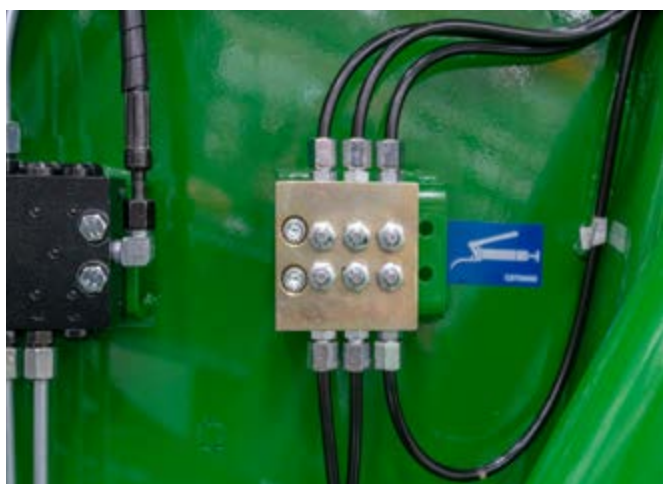

Greasing

All machines come fitted with a number of manual greasing points which are easily accessible throughout the baler either individually or through a centralised greasing block.

The following bearings highlighted below are greased:

Automatic Greasing

Automatic greasing is available as an option on all McHale V8950 machines. A pressurised system delivers a measured amount of grease around the baler every time a bale is ejected from the bale chamber. Automatic greasing saves time as it reduces the amount of manual greasing to be done by the operator. A lube alarm sounds after 300 bales to inform the operator to refill the grease cartridge.

For more information please see the range of options available on [page 23](#).

1 Bale Chamber Drive Side

2 Bale Chamber Non-Drive Side

3 Rotor Bearings Drive Side

4 Rotor Bearings Non-Drive Side

Machine	V8940	V8950
Centralised Greasing Blocks	Standard	Standard
Automatic Greasing	Not Available	Optional

HIGH PERFORMANCE NETTER

A high performance netter has been **DESIGNED AND DEVELOPED** for the McHale variable chamber baler range. This netter is very reliable and features:



Endless Adjustment

Endless adjustment of tension to ensure **optimum net usage** and bale shape

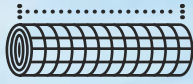

Up to 1300mm

Capacity to take rolls of net wrap up to **1300mm** in width and **4500m** in length



180-Degree Wrap

180-degree wrap around on the rubber feed roller, **eliminating any net slippage** while feeding





Net Stretch Application

A simple yet very effective netting system comprising of a moving roller allows the roll of net to rotate as it is being applied to ensure even net application. Net is stretched around the bale using a hydraulic brake.

The brake places a resistance on the speed at which the roll of net can rotate, the greater the resistance the more stretch that is applied to the net. The operator can adjust net tension without having to leave the comfort and safety of the tractor cab.

Net Layer

The operator can select bale diameter and the number of layers of net to be applied from the control console. The machine will automatically adjust the net application for different bale diameters.

Net Loading & Storage

The operator simply releases the straps on the spare roll of net on the machine platform and moves the roll of net into position. To aid the loading process for the operator, the roll of net can be placed in the net roll loading cradle whilst being threaded through the netter. Once in position, the operator moves the net roll tension bar to hold the roll of net in place. Storage for two extra rolls of net is provided on the baler platform.

Bale Kicker Sensor

McHale V8 balers are fitted with a bale discharge sensor, which notifies the driver when the bale has left the bale chamber and has passed over the bale kicker. The heavy-duty bale kicker ensures a clean separation between the machine and the netted high-density bale.







McHale

22:20
OK
320 m
A
AUTO
000
284
10
125 cm
i

AUTO
MAN
MENU
[Buttons with icons: scissors, cone, stop, arrows, etc.]
EMERGENCY STOP (Red button)
EMERGENCY PLUS

EXPERT PLUS CONTROL CONSOLE

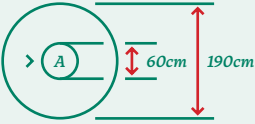
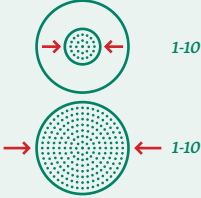
The McHale V8940 and V8950 is fitted with an Expert Plus control console, which has a **LARGE GRAPHIC DISPLAY**. From the control console in the tractor cab the operator can adjust the following;

<p>Core Size & Bale Size</p>	
<p>Core Density & Bale Density</p>	
<p>Revolutions of Net Being Applied</p>	

The McHale Expert Plus Control Console also features:

<p>Knife Display</p>	<p>Door Position Display</p>
<p>Pre-Net Bale Formation Alert</p>	<p>Net Usage (Metres)</p>
<p>Bale Size Setting</p>	<p>Bale Size Display</p>
<p>Drop Floor Display</p>	<p>Lube Count</p>
<p>Lube Alarm</p>	<p>Net Layers</p>
<p>Bale Density</p>	<p>Bale Shape Indicator</p>

Easily Adjusted Bale Settings

The Expert Plus console, also gives the operator the choice of selecting a soft or hard bale core, depending on the customers feed out requirements. The control console can also store ten bale count totals so the operator can record ten different counts that may be associated with different fields or different customers.

Bale Size

The bale diameter can be adjusted on the control console from 0.6–1.9m (2'–6'3"). The preset diameter setting is displayed on the bottom information block on the main screen and a live diameter reading is displayed as the bale is being formed. There is also a vertical bar graph which shows progress as the bale is being made.

Bale density

Bale density and size can be adjusted by the operator on the control console in the tractor cab.

Bale Profiles

A bale profile setting retains the operators personal setting choice from core diameter, bale diameter, core density, bale density, net layers and net stretch for use in different crops. There are 5 bale profile settings to choose from. Each profile will retain its own individual settings so that the machine can easily be changed to work in different crops without needing to change a lot of settings.

Bale Shape Indicators

The V8 variable chamber baler range is fitted with load sensing bale shape indicators, which indicate to the driver via the control console, which side of the chamber needs to be filled. The bale shape indicators ensure that when the machine works in a light swath that the best bale shape is achieved.

The bale shape indicator arrows are also accompanied by a series of beeps so the operator does not need to watch the screen. A low tone is emitted when the operator needs to steer left and a higher tone for when the operator needs to steer right.

VARIABLE BALER RANGE OPTIONS

Options	Camless Pick-Up	Chopper Unit		Selectable Knives	
		15	25	0, 7, 8, 15	0, 12, 13, 25
V8940	Optional	Not Available	Not Available	Not Available	Not Available
V8950	Optional	Standard	Optional	Optional	Optional

McHale machines work in different conditions around the world. To optimise machine performance, **WE OFFER A NUMBER OF OPTIONS** in the Mchale variable chamber range. We recommend you speak with your local dealer/distributor as regards the best configuration to meet your requirements.

Camless Pick-Up

The 2.1m camless pick-up runs smoothly, particularly in short crop, and requires less maintenance due to a reduced number of rotating parts. All camless pick-ups in the Mchale variable chamber baler range are fitted with six tine bars and a double crop roller to provide excellent ground cleaning and fast delivery of crop to the rotor.

Rotor / Chopper Unit

The 25 knife rotor and chopper unit is available as an option on the Mchale V8950 variable chamber machines and delivers a chop length of approximately 46mm.

Selectable Knives

A selectable knife system consists of two knife banks which allow for various knife configurations to be chosen depending on the knife bank specification. If a machine is equipped with 25 knives, then a bank of 12 and a bank of 13 knives are available to be chosen from. Where a machine is equipped with a 15 knife chopping unit, then a bank of 7 and a bank of 8 knives are available to be selected. If no chopping is required then the operator can select for no knives to be engaged. On all V8950 machines, knife selection is engaged from the baler.

Automatic Greasing

Automatic greasing is available as an option on all Mchale V8950 machines. Automatic greasing saves time as it reduces the amount of manual greasing to be done by the operator. All drive and non-drive side chamber bearings and rotor bearings are greased as the machine is working through the automatic greasing cycle. A measured amount of grease is distributed around the machine every time the bale chamber door opens on the V8950 machines. A lube alarm sounds after 300 bales to inform the operator to refill the grease cartridge.

1000rpm Gearbox

Mchale machines work in different conditions around the world so in order to optimise machine performance, a 1000rpm gearbox is available as an optional upgrade on all machines in the Mchale V8 variable chamber baler range.

Tyre Options

A number of tyre options are available to meet your requirements. Please see the table below for the tyre options available to suit your machine of choice.

Machine:	V8940	V8950
Standard:	460/65/20	500/50/22.5
Option 1:	500/50/22.5	560/45/22.5
Option 2:	560/45/22.5	—



Greasing	1000rpm Gearbox	Tyre Options	Brakes	
Automatic Greasing			Hydraulic	Air
Not Available	Optional	500 / 50 / 22.5 560 / 45 / 22.5	Optional	Optional
Optional	Optional	560 / 45 / 22.5	Optional	Optional



VARIABLE BALER RANGE TECH TABLE

V8
940

V8
950

DIMENSIONS & WEIGHT

Length	5.1m (16' 9")	5.1m (16' 9")
Width	2.58 / 2.62* (8' 6" / 8' 7")	2.58 / 2.62* (8' 6" / 8' 7")
Height	3.07m (10' 1")	3.07m (10' 1")
Weight	4,550kg (10,031 lbs)	4,850kg (10,692 lbs)

PICK-UP

Working Width	2100mm (6' 11")	2100mm (6' 11")
Tine Bars	5	5
Tine Spacing	70mm	70mm
Short Crop Guard	Standard	Option
Crop Roller	Option	Standard
Pick Up Guide Wheels (pneumatic)	Standard	Standard

CHOPPER UNIT

Number of Knives	0	15
Theoretical Chop Length	-	65mm
Knife Protection	-	Hydraulic
Knife Deactivation	-	Hydraulic from Cab
Unblocking System	Drop Floor	Drop Floor

BALE CHAMBER

Diameter	0.6 m (2') to 1.9 m (6' 3")	0.6 m (2') to 1.9 m (6' 3")
Width	1.23m (4')	1.23m (4')
Bale Chamber Feed	High Intake Feed Rotor	15 Knife Chopper Feed Rotor
Number of Belts	3	3

NET WRAP

Control	Manual or Automatic	Manual or Automatic
Net System	High Performance Netter	High Performance Netter
Net Roll Capacity	1 + 2 Storage	1 + 2 Storage
Net Adjustment	In Cab	In Cab

TRANSMISSION

Gearbox	Split Drive	Split Drive
Main Drive Protection	Cam Clutch	Cam Clutch
Pick-Up Protection	Slip Clutch	Slip Clutch
Chain Lubrication	Continuous	Continuous
Bale Chamber	Primary Drive	Double Drive

CONTROL

Control System	Expert Plus	Expert Plus
Operation	Semi-Automatic	Semi-Automatic
Density Adjustment	In Cab	In Cab
Bale Size Adjustment	In Cab	In Cab

OTHER

Axle	8 Stud	8 Stud
Tyres Standard	460/65/20	500/50/22.5
Tyres Optional	500/50/22.5 or 560/45/22.5	560/45/22.5
Bale Kicker	Standard	Standard
Road Lights	Standard	Standard

TRACTOR

Minimum Hydraulic Flow	30 Litres / min at 180 bar	30 Litres / min at 180 bar
Hydraulic System	2 double acting spools, 1 free flow return	2 double acting spools, 1 free flow return
Electronics	12 Volt DC, 20 amp	12 Volt DC, 20 amp
Minimum PTO Requirements	55 kW (73hp)	60 kW (80hp)

* Width will depend on tire selection

Higher specification over the V8940



11 - 20 - 001

M-Hale

Ballinrobe,
Co. Mayo,
Ireland

T. 353 (0) 94 95 20300
F. 353 (0) 94 95 20356
E. sales@mchale.net

WWW.MCHALE.NET

Distributed by:

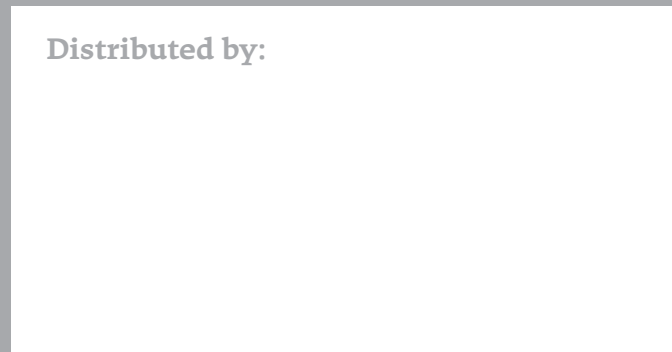

DISCLAIMER: This literature is designed for worldwide circulation. Due to a continuing policy of product improvement, we reserve the right to alter specifications and constructions without notice. As machines are exported to many different countries, general information, pictures and descriptions are provided; these should be taken as approximate and may include optional equipment that is not part of the standard specification. Please consult your local dealer or distributor for further information.